

**NOTE "A"**  
Beam Support Pockets Must be Secured with 1/2" Dia. Concrete Inserts or Anchor Bolts to Maintain Load Requirements.  
**Failure to do so will cause Load Failure and Void Manufacturers Warranty.**

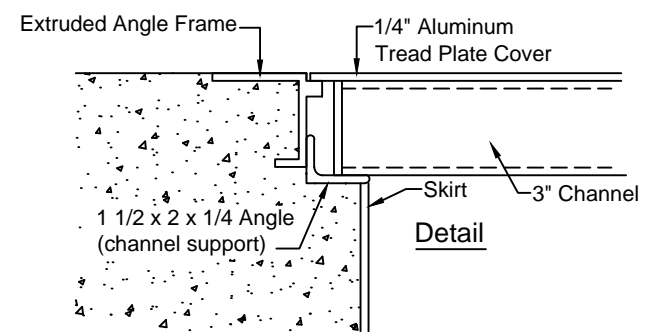

- Note:
1. Extruded Angle Frame
  2. H-20 Loading Incidental Traffic Only
  3. Spring Assist
  4. (316) SS Hardware & Hinges

Aluminum Double Leaf H20 Access Hatch  
DHA4848AL 48 x 48 I.D. (8" Frame Height)

K&B Steel (Formerly Access Products, Inc.)  
E-Mail: kbsteel@valornet.com  
525 Industrial Blvd. Clarksville, Texas 75426  
Phone: (903) 427-3980 FAX: (903) 427-5817

